

Rollz Motion Electric – Travel Guide

This guide is based on the information available at the time it was created. It is possible that the information in this document will be changed. The Rollz Motion Electric can be slightly different to the one described in this guide and the flight regulations could change over time.

Rollz® International BV cannot be held responsible for technical errors or imperfections in this guide.

CE conformity

The Rollz Motion Electric fulfils the requirements of the EU-Directive 93/42 EEC for medical devices. Based on the classification rules set out in Attachment IX of this directive, the product is classified into class I. The declaration of conformity has been done under the own responsibility of Rollz® International BV based on the Attachment VII of this directive.

International standards

The Rollz Motion Electric is certified as a rollator according to ISO standard 11199-2:2005. The Rollz Motion Electric is also certified as a wheelchair in accordance with ISO standard 7176-8: 2014 (Cor. 2015-09). The Rollz Motion Electric is certified as a class A electric wheelchair in accordance with ISO 12184:2014. The battery of the Rollz Motion Electric is certified as passenger travel safe according to UN38.3.

Flight regulations for electrical aids

Traveling with the Rollz Motion Electric is possible, but due to the battery of the Rollz Motion Electric you must take a few safety precautions into account. A battery qualifies as dangerous goods, which means that it must be handled with care. This guide describes a step by step process for traveling with the Rollz Motion Electric by air.

It is important to mention that within the European Union; airlines, tour operators and airports are required by law to assist people with reduced mobility to make normal use of the air travel systems, provided this can be done safely.

Please first read this document and follow the steps listed to prepare for air travel with the Rollz Motion Electric.

The battery pack

The main reason for the stricter flight procedures is because of the battery system. The Rollz Motion Electric makes use of Lithium-Ion batteries (Figure 1) with a capacity of 288 watt-hour. The battery used in the Rollz Motion Electric is UN38.3 certified (Figure 2), meaning that they are safe to be transported by passenger airplanes. The full certificate can be downloaded from our website (the Table in the next chapter contains references).



Figure 1: Rollz Motion Electric Battery pack



		中国认可 国际互认 检测 TESTING CNAS L5998	Test Report issued under the responsibility of 
TEST REPORT UN38.3, Sixth Edition Recommendations on transport of dangerous goods, manual of test and criteria, Section 38.3 - Lithium metal and lithium ion Batteries			
Report Reference No.	19PNS120141 01001		
Date of issue	2019-12-27		
Total number of pages	13 pages		
Testing Laboratory	GUANGDONG UTL CO., LTD. 广东联鼎检测科技有限公司		
Address	Liangding Testing Building, No.18 Center Road of Yayuan Industrial Zone, Nancheng District, Dongguan, Guangdong, China. 东莞市南城街道雅园工业区中心路18号联鼎检测大厦		
Tested by (name + signature)	Seny Yang/Project Engineer 杨宇朋/项目工程师		
Reviewed by (name + signature)	Cindy Wu/Senior Engineer 吴顺娣/资深工程师		
Approved by (name + signature)	Sophie Wu/Chief Engineer 吴娟/主管工程师		
Applicant's name	Shenzhen Bobes Technology Co., Ltd 深圳市博贝斯科技有限公司		
Address	Room 1448, Yongjingxuan Commercial Building, 134 Huasheng Road, Dalang Street, Longhua District, Shenzhen, China 深圳市龙华区大浪街道华盛路134号雍景轩商业大厦1448室		
Manufacturer's name	Dongguan Bobes New Energy Technology Co., Ltd. 东莞市博贝斯新能源科技有限公司		
Address	2nd Floor, Building a2, 8th Courtyard, Shanxia Industrial Zone, Hengli Town, Dongguan City, China 东莞市横沥镇山厦工业区8号院A2栋二楼		
Phone number/联系方式	+86-769-83737389		
Email/邮件地址	1014861942@qq.com		
Website/网址	https://bobeisi.cn.made-in-china.com		
Test specification/测试规范	Standard		
	ST/SG/AC.10/11/Rev.6/Amend.1/Section 38.3		
Test procedure	N/A		
Non-standard test method	N/A		
Test item description/样品名称	Li-ion Battery Pack / 锂离子电池组		
Trade Mark/商标	N/A		
Model/Type reference/型号	BBS-2412-2		
Ratings/规格	24V, 12Ah, 288Wh		



Figure 2: Front page of the Rollz Motion Electric UN38.3 certificate

Register the Rollz Motion Electric

To go on a flight with an electrical aid, you must always first contact the company through which you booked the trip. This concerns the airline, the tour operator, or the travel agency. Together you will walk through the registration process, and they will take the necessary steps to inform the airport authorities of your request.

Make sure to have the correct information about the Rollz Motion Electric ready, like the Table below and the certificate for safe transport ready (see table for reference).

Table

Important information about travelling with the Rollz Motion Electric	
<i>Required data</i>	<i>Rollz Electric Specifications</i>
Manufacturer	Rollz International
Model version	Rollz Motion Electric
Special Service Request code	WCLB
Contains a battery	Yes
Battery type	Lithium-Ion
Battery power	288 Wh (watt-hours)
Battery designed for disconnection	Yes
Total weight mobility aid	26 kg (excluding accessories)
Foldable	Yes
Dimensions (folded)	71 x 44 x 90 cm (d x b x h)
Dimensions (unfolded without parts)	110 x 74 x 91-96 cm (d x b x h)
Removable or adjustable parts	Yes: footrests, joystick, push support controller, seat, battery & possible purchased accessories.
User manual	
UN38.3 certificate	

It is mandatory to register traveling with your Rollz Motion Electric at least 48 hours before the flight. If you fail to do so and report it after the 48 hour deadline, there is little chance that the Rollz Motion Electric will be accepted on the flight.



Please note that only a limited amount of (electrical) aids can be taken on each flight. The earlier you register, the higher the chances for a place for your Rollz Motion Electric.

The specific procedures differ by airlines. To be fully prepared for your trip, always consult their website. When registering the Rollz Motion Electric by phone, always ask what is expected of you upon arrival at the airport.

Preparations before leaving to the airport

Before departing to the airport, it is important to have several products and documents ready. If you are traveling with the Rollz Motion Electric for the first time, you may need to purchase some parts in advance, so make sure to allow enough time for this. The necessary products and documents include:

- Information or documents you received when registering your device. This differs per airline.
- Rollz Motion Electric Manual (either online or physical).
- Rollz Motion Electric Travel Guidance (either online or physical).
- UN 3480 certificate (either online or physical).

Depending on the airline, you may need to bring the following accessories (check beforehand):

- Travel cover or any other protective cover.
- Connector caps or non-conductive tape.
- Travel bag to store loose parts.
- Lithium-ion battery safety bag.

Airport procedure

You may need to arrive at the airport earlier than usual due to special procedure. This provides the staff at the check-in counter enough time to assist you in the process. Check the website of your airline or contact the company where you booked the trip.

Upon arrival at the airport, you will need to hand in the Rollz Motion Electric at the check-in desk of the airline. Depending on the flight you may be asked to either check-in the Rollz Motion Electric or take it with you to the airplane. You may be asked to prepare your Rollz Motion Electric for travel yourself, or to assist airport staff in getting it ready for travel.

Follow the steps below to prepare the Rollz Motion Electric for travel.

Disconnecting and removing the battery

Turn off the Rollz Motion Electric, apply the parking brake, do not sit in the wheelchair and position the Rollz Motion Electric on a flat surface before removing the battery.

Find the battery cable and disconnect the battery cable by turning the metal ring on the connector anticlockwise. You can find the battery cable in the basket under the seat. After disconnecting the cable you can unwrap the Velcro strips to take out the battery (Figure 3).

After removing the battery from the Rollz Motion Electric, you will have to depolarize the connectors by using insulating tape. Afterwards put the battery in a protective bag.

1

Press power button on joystick or push support to turn system off

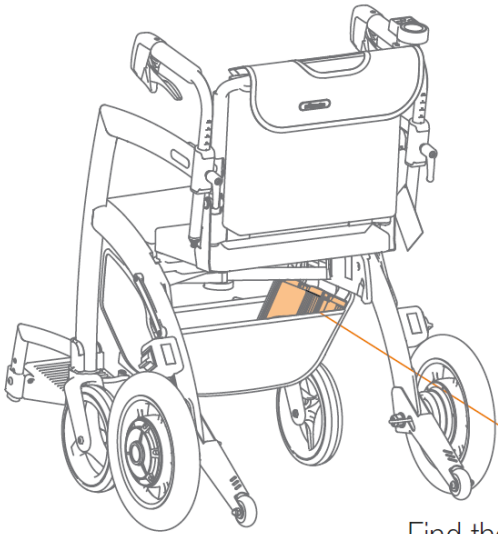
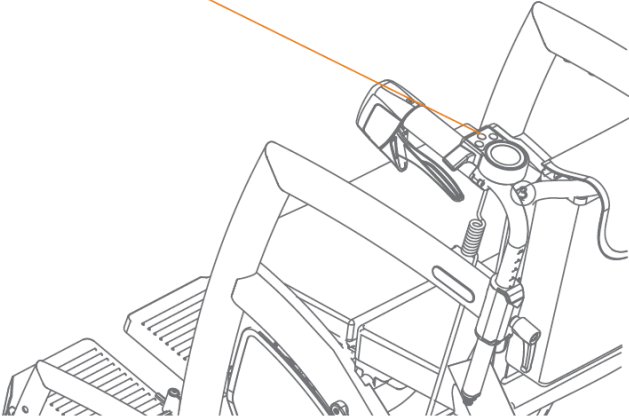
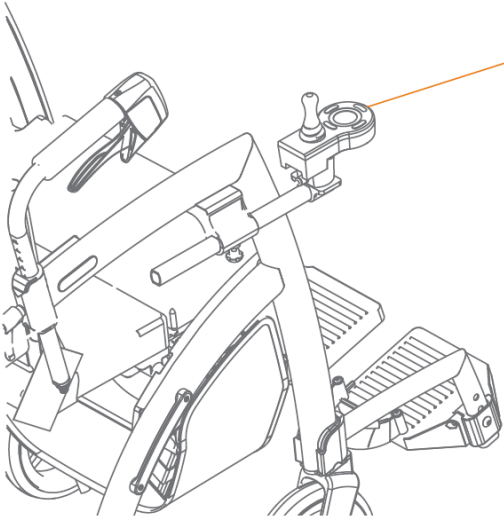

2

Find the battery cable on the left side in the basket underneath the seat.

3

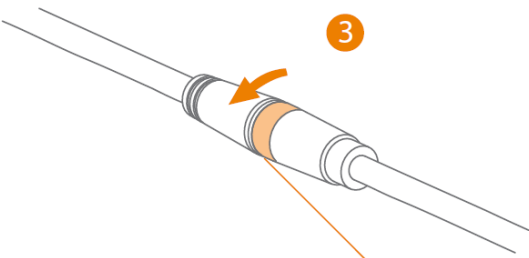

Disconnect the battery from the motor controller by turning the metal ring counter-clockwise.

Figure 3

Putting down the wheelchair package

Follow these steps to turn the electric wheelchair into a rollator:

1. Remove the footrests. Slide the footrests up until released from the footrest holders. Put them back into the bag of the Rollz wheelchair package, mirrored to each other (Figure 4).
2. Grasp the handle of the wheelchair package and push the backrest forward until halfway up the frame. Then lower the backrest down until it folds behind the seat.
3. Loosen the adjustment handles anticlockwise and turn the handles outwards until they point straight forward. Set to the lowest height and tighten the adjustment handles clockwise.
4. The wheelchair package stays in place when folded under the seat and the rollator can be used to walk.

Removing the wheelchair package

1. Pull up the red handle without force. This way the locking bolts are tied in, and the wheelchair package unlocked (Figure 5).
2. Hold the handle of the wheelchair package and pull it up without force.
3. Then push down the red handle.
4. The package can now be stored. The footrests remain inside the package.

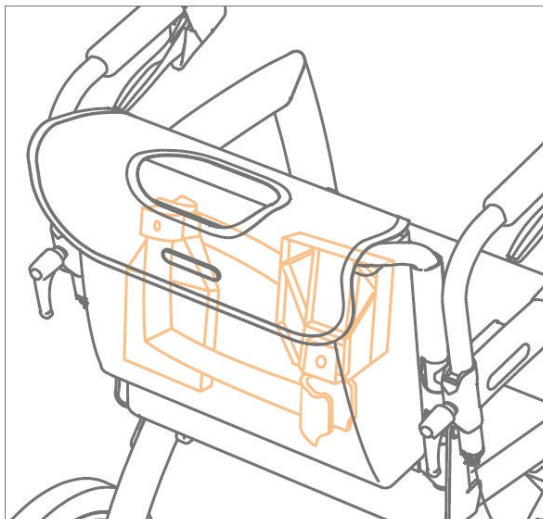

Figure 4

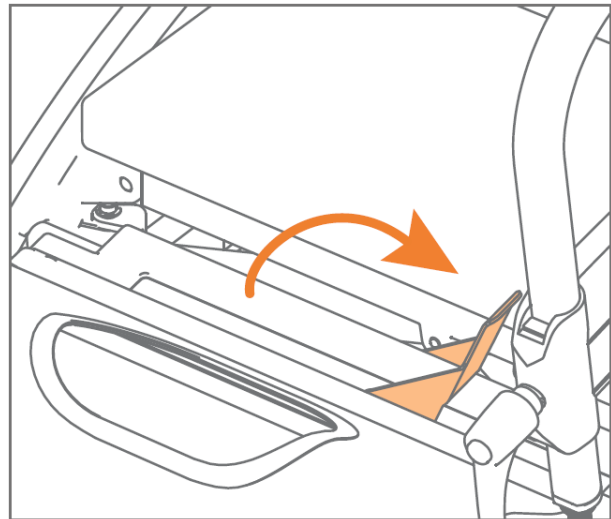

Figure 5

Disconnecting the loose parts

Before you can store the Rollz Motion Electric for your flight, the removable parts must be disconnected and put away. Otherwise, these parts may be damaged during transport.

- ! You will likely be held responsible for transporting these loose parts, so make sure to bring a bag to safely transport them.

Disconnecting the push support controller

Disconnect the push support controller by sliding it off its position (Figure 6).

Disconnecting the joystick controller

1. Make sure to disconnect the joystick controller wiring before removing the joystick holder. Loosen the joystick controller by untightening the nut and disconnect the joystick cable by twisting the cable rings (Figure 7).
2. Slide the disconnected joystick controller through the hole in the holder (Figure 8).

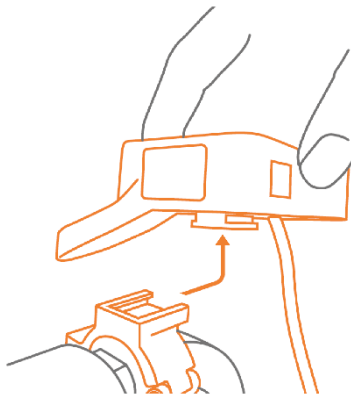

Figure 6

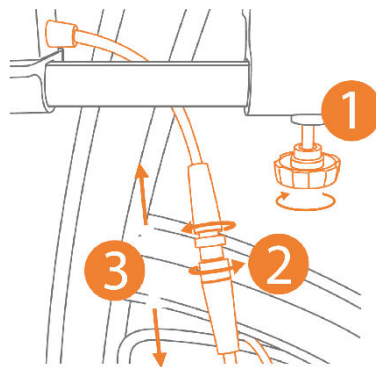

Figure 7

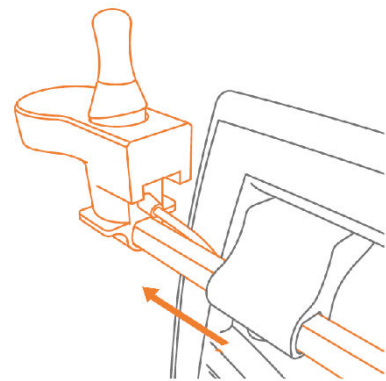

Figure 8

Disconnecting accessories

Do you use Rollz accessories? Then you will also have to disconnect these parts from the Rollz Motion Electric. Consult the manual of the corresponding accessory for disassembling instructions.

Folding of the rollator

1. Before folding the frame, the under seat basket should be emptied, except the cables and motor controller which must be kept in the under seat basket.
2. Pull the seat cushion away, turn it 90 degrees and place it crosswise on the side, above the red handle (Figure 9).
3. Push the red release handle under the seat (Figure 10) and lift the seat partially (Figure 11).
4. Push the sides of the frame towards each other until the rollator is completely folded (Figure 12).

NOTE

When you fold the frame, the under seat basket should only contain the cables, battery pack and motor controller, and the wheelchair package should be detached.

Only lift the Rollz Motion Electric by frame parts as shown in Figure 13.

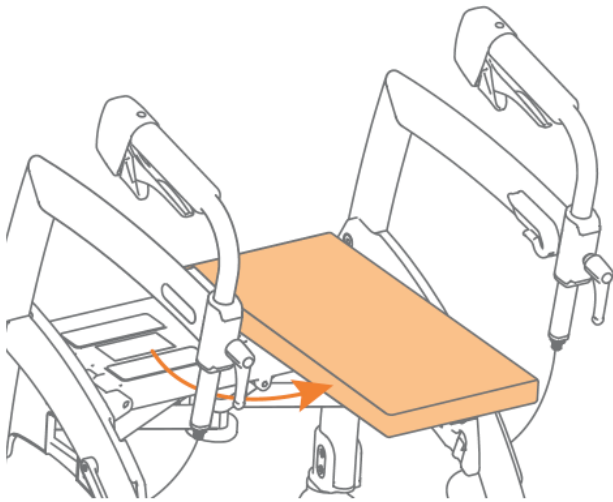

Figure 9

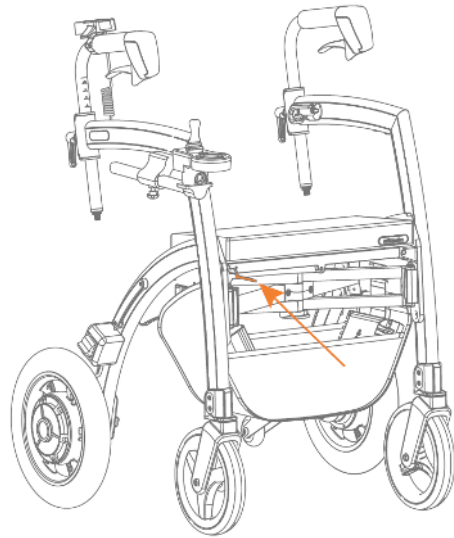

Figure 10

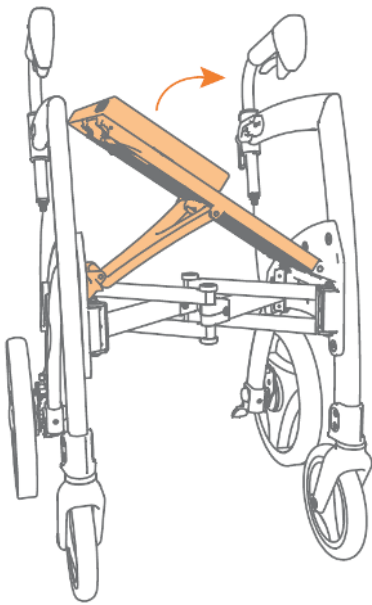

Figure 11

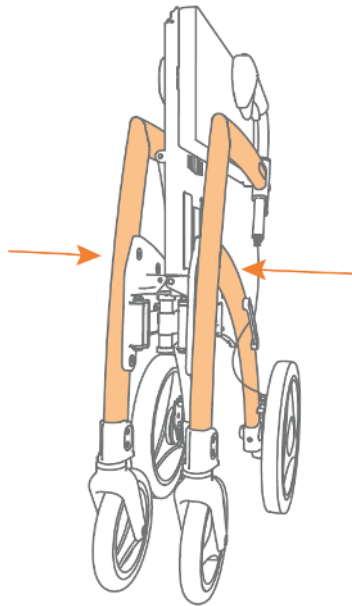

Figure 12

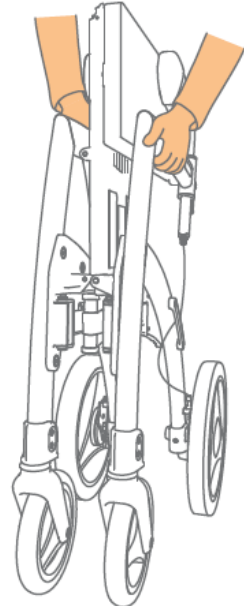

Figure 13

Checking in the Rollz Motion Electric

Check in the Rollz Motion Electric at the check-in counter of the airline. You can then use the airport's special aid facilities.

Tip: Arrange your airport transportation in advance through the contact centre. They will discuss the options with you. Are you specifically dependent on the Rollz Motion Electric to get to the gate? This is possible with some airlines, so please contact the airport for the possibilities.

It is important to note that in most cases you will be asked to bring the bag of loose parts and battery to the gate yourself. If in a specific case your Rollz Motion Electric is transported in the cabin, you could also be held responsible for transporting it to the gate. So keep in mind that you may need to take more carry-on baggage. The rules can vary per flight.

For assembly of your Rollz Motion Electric, please read the original Rollz Motion Electric user manual.